

THE SWEED MODULAR SERIES

SMALL FOOTPRINT WIRE & CABLE SEPARATION SYSTEM



Start small. Grow big. Reap rewards. These are the key elements behind Sweed's new wire and cable separation system. It offers a small footprint design, engineered for big results, and is the future in wire and cable handling systems. Simply said: as your needs grow, the system grows with you.

- Run high volumes of mixed scrap or focus on small amounts of specific materials.
- Operator and maintenance friendly.
- Made in the USA and backed by over 17 years of cable separation experience.

From the electrical panel to the design, this system has the ability to add additional Sweed component(s) as your volume increases. Expansion is simple and can be done in steps: adjoin a Sweed 5703 rotary shear to process large coiled material, a Sweed Prechopper can also be added to increase throughput, and if two air tables are too much, Sweed can configure your system with one table (with room to add a second later on).



SMALL FOOTPRINT

Sweed has answered the requests of small-volume processors by supplying a separation system that doesn't require much space, yet provides good clean results. Sweed prides itself in being a manufacturer in the United States; providing helpful technical support, outstanding customer service, and stocking replacement parts.



ONE TOUGH GRANNY

Quality craftsmanship and innovative design are just two key elements that set Sweed's separation systems aside from others on the market. One unique feature on Sweed Granulators is the footswitch controlled chute gate to the quick change screens via a hydraulic carriage; this makes changing screens to the granulator a cinch! Sweed Granulators come in three sizes, and all three are built like tanks (the 18x26 is standard on the base Modular System).



DUAL AIR TABLES

Sweed incorporates two air tables into their separation system design. This adds more flexibility for the end user, allowing different materials to be processed at once; providing more throughput with better recovery. In addition, Sweed has separated the Rotary Air Lock from the Air Table(s). This enables the operator to have quick access to material on the tables, and allows the operator to easily make adjustments as needed.



QUALITY RESULTS

We want your business to grow (and we don't want our equipment to become obsolete when it does)! As a result, Sweed's Modular Series is designed to expand as your volume increases. From the electrical panel, all the way to the layout, this system is designed to help you obtain maximum production levels no matter how small or big your business is.



DESIGNED TO GROW

Sure there are other separation systems on the market, but we challenge you to find one that provides: a small footprint, is stout and durable, produces impeccable separation results and is made by a company in the USA that provides rapid service, parts, and technical assistance. Sweed has been manufacturing separation systems for nearly two decades. You can trust Sweed to be your partner in separation.

TOLL FREE: 1-800-888-1352 • WWW.SWEED.COM

BASE SYSTEM

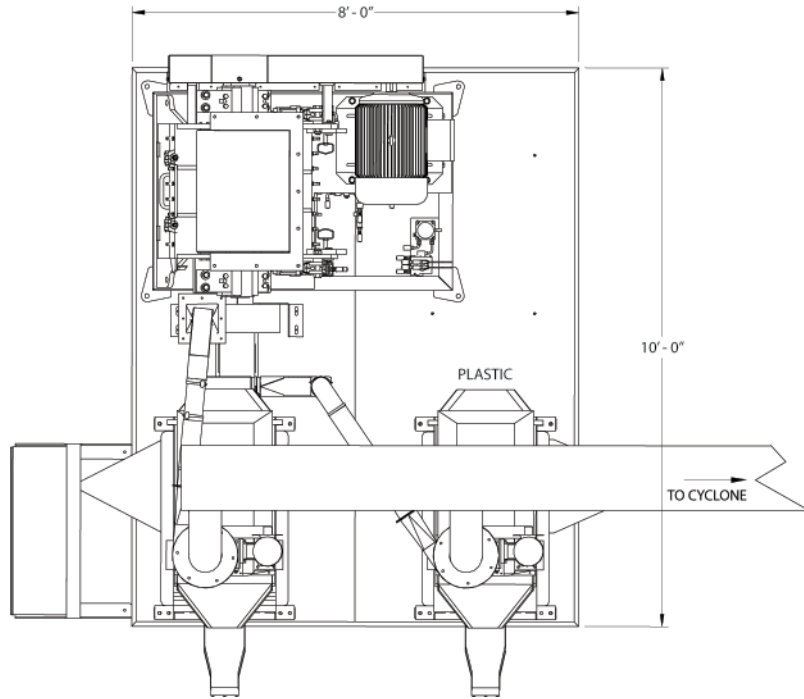

PERFORMANCE DATA

- Input Production—Base System500-800 LBS/HR
- Input Production—with PCR 1034 Prechopper Option*1000-1600 LBS/HR
- 18 x 26 Granulator.....40 HP
- Granulator Discharge Blower3 HP
- PCR 1034—Optional Prechopper*30 HP
- Prechopper Outtake Conveyor*3/4 HP
- Magnetic Cross-Belt*3/4 HP
- Booster Blower3 HP
- Dust Collection15 HP
- Table 15 HP
- Table 25 HP
- Table 1 Air Lock1/2 HP
- Table 2 Air Lock1/2 HP
- Cyclone Air Lock.....1/2 HP

ELECTRICAL REQUIREMENTS

- 3 phs 460 - 96 Full Load Amps
- 138 FLA Needed with Optional Prechopper and Magnetic crossbelt*

* Denotes options that can be added to the base system.

STANDARD FEATURES

- Durable & Built to Withstand Harsh Environments
- High Purity End Results
- Free Standing Control Panel (designed to make additions)
- Touch Screen Interface (with flexibility to expand to larger system)
- Control Panel Log (to keep track of your production and materials)
- Full Load Indicator Light (for operator)
- Air Lock for Main Cyclone
- Air Lock for Each Air Table
- Sight Glass on Each Air Table
- Modular Ducting with "Quick Release" replaceable joints
- Footswitch Actuated Infeed Hopper (granulator)
- Easy Hydraulic Quick-Change Granulator Screen Carriage
- Replaceable Wear Plates
- Two Screens Included (sizes dependant on requirements)
- Simple and Minimal Maintenance Required

OPTIONAL FEATURES

- PCR1034 Pre-Chopper (effectively doubles throughput—depending on material)
- Model 5703 XHD Scrap Chopper (to despool and chop large cable off reels)
- Skid Mount For Granulator & Separation Portion
- Ability To Separate Steel (requires magnetic cross-belt)
- Granulator Infeed Conveyor (with mag head)

