



CC-5B Series Crushers

From *Recycling Equipment Manufacturing, Inc.*

“THE BEER, SOFT DRINK, AND JUICE DRINKER”



CRUSH THE CANS...
PERFORATE THE PET...
FRESH WATER RINSE...
LIQUID FLOWS INTO DRAIN...

Process “line rejects” or “out dated product” and recover aluminum cans and PET Containers for recycling with REM® Series 5B Crushing System. Our Model CC-5B crushes aluminum cans while our Model CC-5B PERF processes both PET Containers as well as aluminum cans. Each model comes complete with an in-feed conveyor, totally enclosed crushing mechanism, capture tank with drain, and an out-feed conveyor with fresh water rinse.

PROVEN DESIGN

Product is loaded on the in-feed conveyor hopper and is conveyed up into REM's® Crusher (CC-5B) or perforator mechanism (CC-5B PERF) where the containers are crushed with the beverage fluid discharging into the capture tank. The beverage containers are then discharged on the out-feed conveyor belt where they run under a fresh water rinse aiding in the removal of residual beverage fluids. The containers are then discharged in a container, REM® Model CB Can or PET Bottle Blower, or a baler. For even greater processing capability, look to our CC-10B PERF. To put our model CC-5B or CC-5B PERF to work for you, call **1-800-745-4736**.



CC-5B Series Crushers

A Leader in Recycling Equipment Since 1978

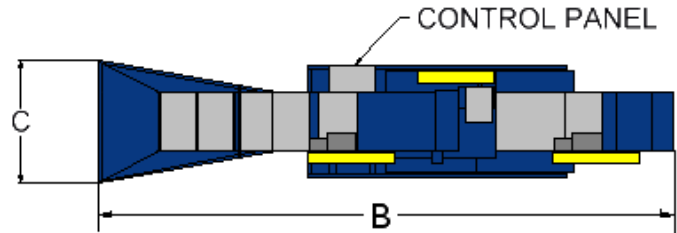
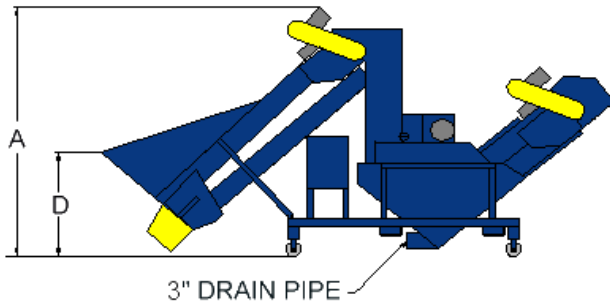

Features:

- Second generation field-proven design for high volume, low maintenance, and easy service
- Enclosed tail pulley cover with external take-ups for correct belt tracking and tension
- Low in-feed hopper for easy loading/visual inspection
- Enclosed belt and chain guards for user protection
- Fresh water rinse on out feed conveyor
- Processes up to 600 cases of aluminum cans or up to 3000 PET bottles per hour.

Specifications:

- All steel unitized construction
- PVC-150 conveyor belting with vulcanized cleats and Flexco 125 Megalloy Lacing
- 8" diameter head pulley, and 6" diameter crowned tail pulley
- 6" industrial steel casters
- Enclosed sides and bottom of belt return pan
- 1/2 HP TEFC conveyor motor
- 5 HP TEFC crusher motor

Electrical safety features:

- 240/480 volt, three phase
- Electrical components are UL listed
- NEMA-4 (hose proof) enclosure
- Sequential manual start motor controls
- Main safety fused disconnect
- Individual motor overload/short circuit protection
- Safety interlock on crusher access door

Dimensions:	CC-5B	CC-5B Perf
Height (A)	8' 4"	8' 4"
Length (B)	16'	16'
Width (C)	3' 8"	4' 2"
Loading height (D)	3' 4"	3' 7"
Weight approx. (lbs.)	2100	2275
Hopper:		
Capacity (in 16")	1/3 cu. Yd.	2/3 cu. Yd.
Conveyor:		
Discharge height	4' 5"	4' 5"
Belt width	16"	24"
Cleat size	1-1/2"	3"
Crushing drum:		
CC-5B	16" wide welded steel cleats	
CC-5B PERF	24" wide welded steel teeth	
Density:		
CC-5B	5-6lbs. Per cu.ft. (Aluminum cans)	
CC-5B PERF	35-50% Size reduction on PET Containers	
	2-4 lbs. Per cu.ft. (Aluminum cans)	

Options:

- 240 volt, single phase
- Stainless steel upgrade
- 208, 380, 415, 480, or 575 volt, three phase
- Power cord
- Custom conveyors, hoppers, discharge heights
- Pump for fluid capture tank
- Wash-down duty bearings
- If you don't see it, ask us!

LIMITED ONE YEAR WARRANTY

*All dimensions are nominal +/- 1"

*Specifications subject to change without notice, without incurring responsibility to previous units sold

Recycling Equipment Manufacturing, Inc.

PO Box 310
 Priest River, Idaho USA 83856
 www.remfg.com
 E-mail: sales@remfg.com
 1-800-745-4736
 Office: (208) 448-4736
 Fax: (208) 448-1786

© 2000 REM, INC.

Sales and Service